

3M™ Water Filtration Products

3M™ ScaleGard™ Blend Series of Heads with Local Monitor

Application: Coffee, espresso, vending & steamers

3M™ ScaleGard™ Blend Series of Heads with Local Monitor provides audio and visual reminders when it's time to order a new cartridge and when it's time to replace a cartridge.

3M™ ScaleGard™ Blend Series of Heads with Local Monitor allow end-users to adjust the blend setting to customize water quality. Notably, the head even remembers previous blend settings when replacing cartridges, helping to save you time.

Product Benefits:

- Delivers automatic notifications by audio and blinking light when it's time to order new cartridges and replace old cartridges
- Offers easy-to-operate adjustable dial for precision blending when combined with 3M™ ScaleGard™ Blend Series of Cartridges
- Provides high-quality filtered water that may help protect equipment and profits when combined with 3M™ ScaleGard™ Blend Series of Cartridges



Product Specifications:

Model #	Description	Part #	3M ID
BH3M	Valve-in-head assembly w/blend adjustment, with local monitor & JG fittings	6240803	70020333392
BH3M-NPT	Valve-in-head assembly w/blend adjustment, with local monitor & NPT fittings	6240809	70020333335
BH3M-BSP	Valve-in-head assembly w/blend adjustment, with local monitor & BSP fittings	6240815	70020333277
BH3M-NB	Valve-in-head assembly w/blend adjustment, with local monitor without bracket, & JG fittings	6240805	70020333376
BH3M-NB-NPT	Valve-in-head assembly w/blend adjustment, with local monitor without bracket, & NPT fittings	6240811	70020333319
BH3M-NB-BSP	Valve-in-head assembly w/blend adjustment, with local monitor without bracket, & BSP fittings	6240817	70020333251

3M™ Water Filtration Products

3M™ ScaleGard™ Blend Series of Heads with Local Monitor

Specifications

- 3/8" inlet and outlet plumbing connections available with NPT, BSP and Push-in connections
- Operating pressure of 25-125 psi (172-862 kPa)
- Operating temperature of 40-100°F (4.4 – 37.8°C)

Important: Installation Tips

⚠ WARNING:

Read entire manual. Failure to follow all guides and rules could cause personal injury or property damage.

- Check with your local public works department for plumbing codes. You must follow their guidelines as you install the Water Filtration system.
- Your Water Filtration system will withstand up to 125 pounds per square inch (psi) water pressure. If your water supply pressure is higher than 80 psi, install a pressure reducing valve before installing the Water Filtration system.

To reduce the risk associated with the ingestion of contaminants:

- DO NOT use with water that is microbiologically unsafe or of unknown quality without adequate disinfection before or after the system.

NOTICE:

To reduce the risk associated with water leakage or flooding:

- Read and follow Use Instructions before installation and use of this system.

Spec # _____

Quantity _____

Model # _____

Part # _____

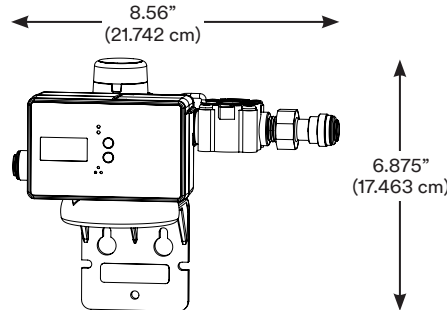

Model(s): BH3M

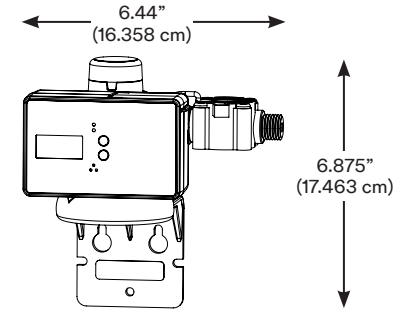

Model(s): BH3M-NPT
BH3M-BSP

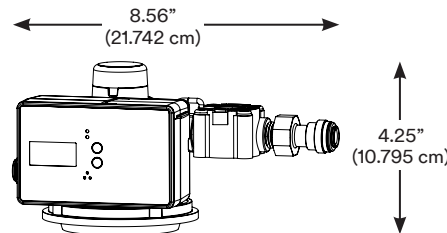

Model(s): BH3M-NB

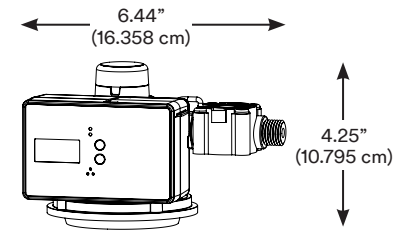

Model(s): BH3M-NB-NPT
BH3M-NB-BSP

Limited Warranty

Warranty, Limited Remedy, and Disclaimer: Many factors beyond 3M's control and uniquely within user's knowledge and control can affect the use and performance of a 3M product in a particular application. User is solely responsible for evaluating the 3M product and determining whether it is fit for a particular purpose and suitable for user's method of application. Unless an additional warranty is specifically stated on the applicable 3M product packaging or product literature, 3M warrants that each 3M product meets the applicable 3M product specification at the time 3M ships the product. 3M MAKES NO OTHER WARRANTIES OR CONDITIONS, EXPRESS OR IMPLIED, INCLUDING, BUT NOT LIMITED TO, ANY IMPLIED WARRANTY OR CONDITION OF MERCHANTABILITY OR FITNESS FOR A PARTICULAR PURPOSE OR ANY IMPLIED WARRANTY OR CONDITION ARISING OUT OF A COURSE OF DEALING, CUSTOM OR USAGE OF TRADE. If the 3M product does not conform to this warranty, then the sole and exclusive remedy is, at 3M's option, replacement of the 3M product or refund of the purchase price.

Limitation of Liability: Except where prohibited by law, 3M will not be liable for any loss or damage arising from the 3M product, whether direct, indirect, special, incidental or consequential, regardless of the legal theory asserted, including warranty, contract, negligence or strict liability.



3M Purification Inc.
400 Research Parkway
Meriden, CT 06450 U.S.A.

Toll Free 1-866-990-9785
Worldwide 1-203-237-5541
Fax 1-203-238-8701
Web www.3Mpurification.com
www.3Mfoodservice.com

3M and ScaleGard are trademarks of 3M Company.
© 2016 3M Company. All rights reserved.
70020340488 REV 0916
Please recycle. Printed in U.S.A.